

SPECIFICATION FOR APPROVAL

REF. :

PROD. NAME	SMD Power Inductor	ABC'S DWG NO.	SQ4532□□□□L□-□□□		
		REV.	20210123-I	PAGE	1

I . Configuration and dimensions :

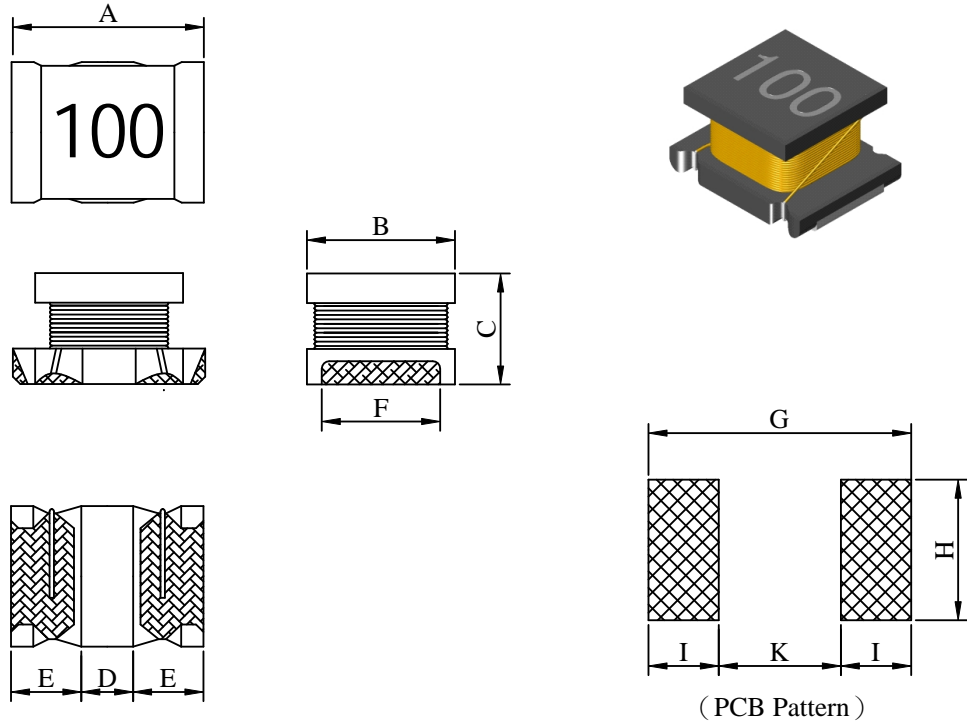

Unit : mm

A	B	C	D	E	F	G	H	I	K
4.50 ±0.3	3.20 ±0.3	2.60 ±0.3	1.30 typ.	1.60 ref.	2.00 ref.	5.40 ref.	3.60 ref.	2.00 ref.	1.40 ref.

II . Description :

- a . Ferrite drum core construction
- b . Enamelled copper wire : H class
- c . Product weight : 0.13g (ref.)
- d . Moisture sensitivity Level 1
- e . Products comply with RoHS' requirements
- f . Halogen free

III . General specification :

- a . Storage temp. : -40°C ----+125°C
- b . Operating temp. : -40°C ----+125°C
(Temp. rise included)
- c . Resistance to solder heat : 260°C.10 secs.

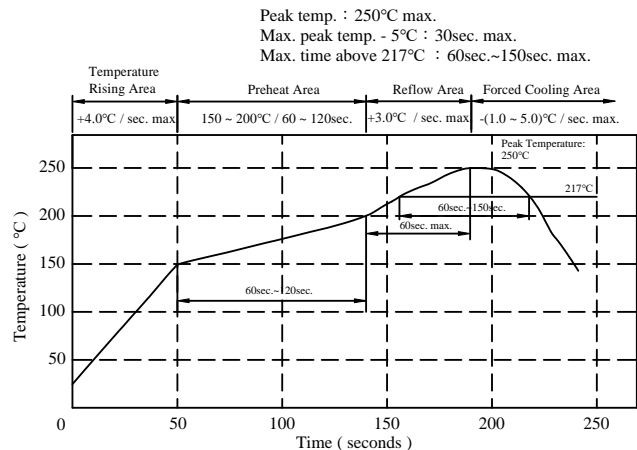

AR-001C

SPECIFICATION FOR APPROVAL

REF. :

PROD. NAME	SMD Power Inductor	ABC'S DWG NO.	SQ4532□□□□L□-□□□		
		REV.	20210123-I	PAGE	2

IV . Electrical characteristics :

DWG. No.	Inductance (μ H)	Q ref.	Test Freq. (Hz)		SRF (MHz) nom.	RDC (Ω) max.	Irms 1 (mA)max. Δ T=20°C	Irms 2 (mA)max. Δ T=40°C
			L	Q				
SQ45321R0ML□-□□□	1.00 \pm 20%	40	1M	1M	165.0	0.080	1400	1800
SQ45321R5ML□-□□□	1.50 \pm 20%	42	1M	1M	130.0	0.090	1350	1750
SQ45321R8ML□-□□□	1.80 \pm 20%	45	1M	1M	100.0	0.100	1300	1700
SQ45322R2ML□-□□□	2.20 \pm 20%	40	1M	1M	80.0	0.110	1250	1600
SQ45322R7ML□-□□□	2.70 \pm 20%	40	1M	1M	63.0	0.120	1200	1500
SQ45323R3ML□-□□□	3.30 \pm 20%	45	1M	1M	58.0	0.130	1000	1400
SQ45323R9ML□-□□□	3.90 \pm 20%	40	1M	1M	54.0	0.140	960	1320
SQ45324R7ML□-□□□	4.70 \pm 20%	36	1M	1M	45.0	0.150	940	1240
SQ45325R6ML□-□□□	5.60 \pm 20%	36	1M	1M	41.0	0.180	920	1180
SQ45326R8ML□-□□□	6.80 \pm 20%	36	1M	1M	37.0	0.200	860	1100
SQ45328R2ML□-□□□	8.20 \pm 20%	36	1M	1M	34.0	0.250	780	1000
SQ4532100ML□-□□□	10.00 \pm 20%	48	1M	1M	30.0	0.300	750	950
SQ4532120ML□-□□□	12.00 \pm 20%	48	1M	1M	28.0	0.420	700	800
SQ4532150ML□-□□□	15.00 \pm 20%	45	1M	1M	26.0	0.500	650	730
SQ4532180ML□-□□□	18.00 \pm 20%	42	1M	1M	22.0	0.600	570	680
SQ4532220KL□-□□□	22.00 \pm 10%	50	1M	1M	20.0	0.700	460	630
SQ4532270KL□-□□□	27.00 \pm 10%	50	1M	1M	19.0	0.900	360	520
SQ4532330KL□-□□□	33.00 \pm 10%	55	1M	1M	18.0	1.100	330	430
SQ4532390KL□-□□□	39.00 \pm 10%	60	1M	1M	17.0	1.300	310	410
SQ4532470KL□-□□□	47.00 \pm 10%	60	1M	1M	15.0	1.500	285	390
SQ4532560KL□-□□□	56.00 \pm 10%	58	1M	1M	14.0	1.600	270	385
SQ4532680KL□-□□□	68.00 \pm 10%	58	1M	1M	11.0	2.100	230	330
SQ4532820KL□-□□□	82.00 \pm 10%	60	1M	1M	11.0	2.200	215	300
SQ4532101KL□-□□□	100.00 \pm 10%	60	1M	796k	10.0	2.500	200	270
SQ4532121KL□-□□□	120.00 \pm 10%	60	1M	796k	9.0	3.000	180	240
SQ4532151KL□-□□□	150.00 \pm 10%	55	1M	796k	8.5	3.700	165	220
SQ4532181KL□-□□□	180.00 \pm 10%	55	1M	796k	7.0	4.500	145	200
SQ4532221KL□-□□□	220.00 \pm 10%	45	1M	796k	6.3	5.400	130	185
SQ4532271KL□-□□□	270.00 \pm 10%	50	1M	796k	6.0	8.000	110	140
SQ4532331KL□-□□□	330.00 \pm 10%	55	1M	796k	5.8	11.500	100	120
SQ4532391KL□-□□□	390.00 \pm 10%	50	1M	796k	5.2	13.000	95	110
SQ4532471KL□-□□□	470.00 \pm 10%	50	1k	796k	5.0	14.200	85	105
SQ4532561KL□-□□□	560.00 \pm 10%	53	1k	796k	4.5	15.500	80	100
SQ4532681KL□-□□□	680.00 \pm 10%	45	1k	796k	3.5	16.800	75	90
SQ4532821KL□-□□□	820.00 \pm 10%	50	1k	796k	2.8	20.000	70	85
SQ4532102KL□-□□□	1000.00 \pm 10%	30	1k	252k	2.5	30.000	60	70
SQ4532122KL□-□□□	1200.00 \pm 10%	30	1k	252k	2.3	33.500	45	60
SQ4532152KL□-□□□	1500.00 \pm 10%	35	1k	252k	2.0	38.500	40	55
SQ4532182KL□-□□□	1800.00 \pm 10%	35	1k	252k	1.8	44.000	35	50
SQ4532222KL□-□□□	2200.00 \pm 10%	30	1k	252k	1.6	47.000	30	40

- 1). Electrical specifications at 25°C
- 2). Inductance drop 10% max. at rated Irms

AR-001C

SPECIFICATION FOR APPROVAL

REF. :

PROD. NAME	SMD Power Inductor	ABC'S DWG NO.	SQ4532□□□□L□-□□□		
		REV.	20210123-I	PAGE	3

V . Curve :

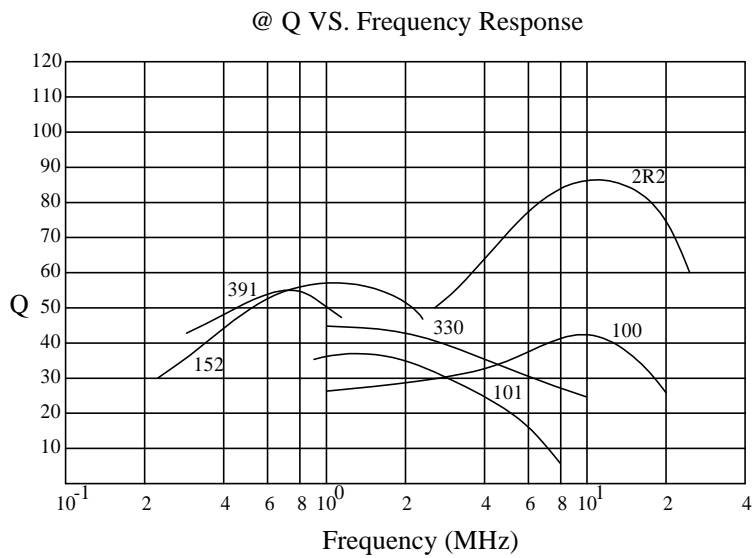
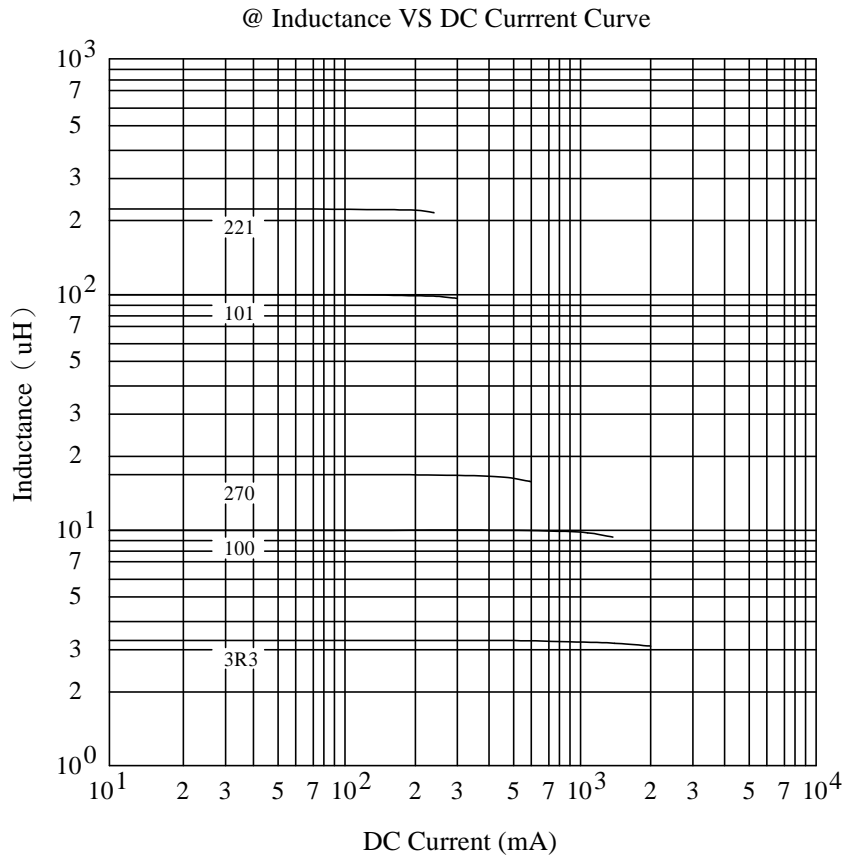

AR-001C

SPECIFICATION FOR APPROVAL

REF. :

PROD. NAME	SMD Power Inductor	ABC'S DWG NO.	SQ4532□□□□L□-□□□		
		REV.	20210123-I	PAGE	4

VI . Packaging information :

(1) Configuration

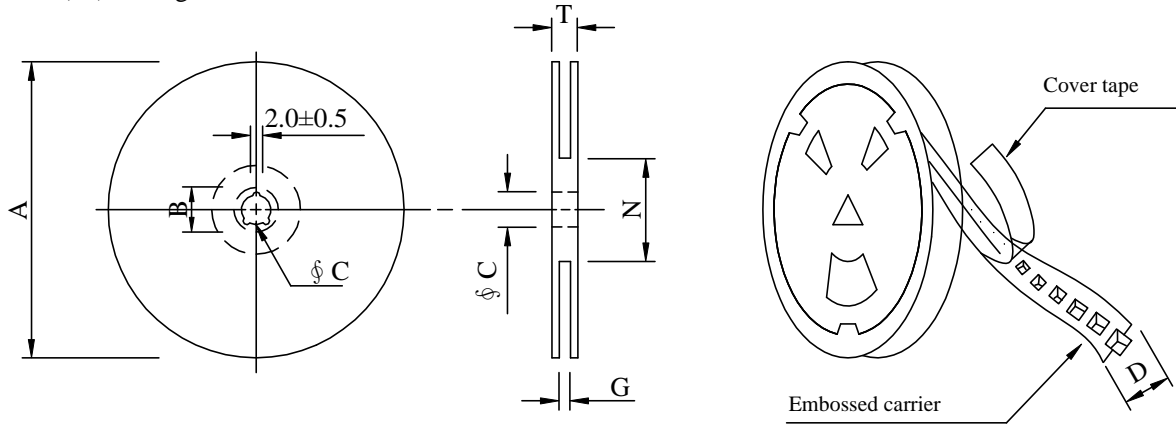

※Carrier tape width : D

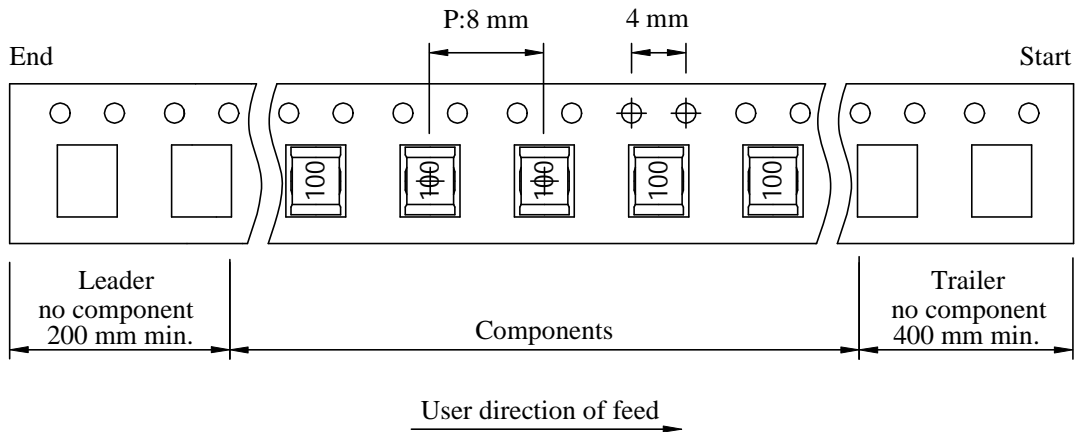

(2) Dimensions

Unit:mm

Style	A	B	C	D	G	N	T
07 - 12	178	21±0.8	13	12	14 ⁺⁰	50 ⁻⁰	16.5
13 - 12	330	21±0.8	13±0.5	12	14 ⁺⁰	50 ⁻⁰	18.4

(3) Q'TY & G.W. Per package

Code	Inner : Reel			Outer : Carton		
	Q'TY (pcs)	G.W. (g)	Style	Q'TY (pcs)	G.W. (kg)	Size (cm)
B	500	170	07 - 12	20,000	8.10	42 x 41 x 24
C	2,000	620	13 - 12	16,000	6.20	38 x 37 x 22

AR-001C

SPECIFICATION FOR APPROVAL

REF. :

PROD. NAME	SMD Power Inductor	ABC'S DWG NO.	SQ4532□□□□L□-□□□		
		REV.	20210123-I	PAGE	5

VII . Drawing number expression :

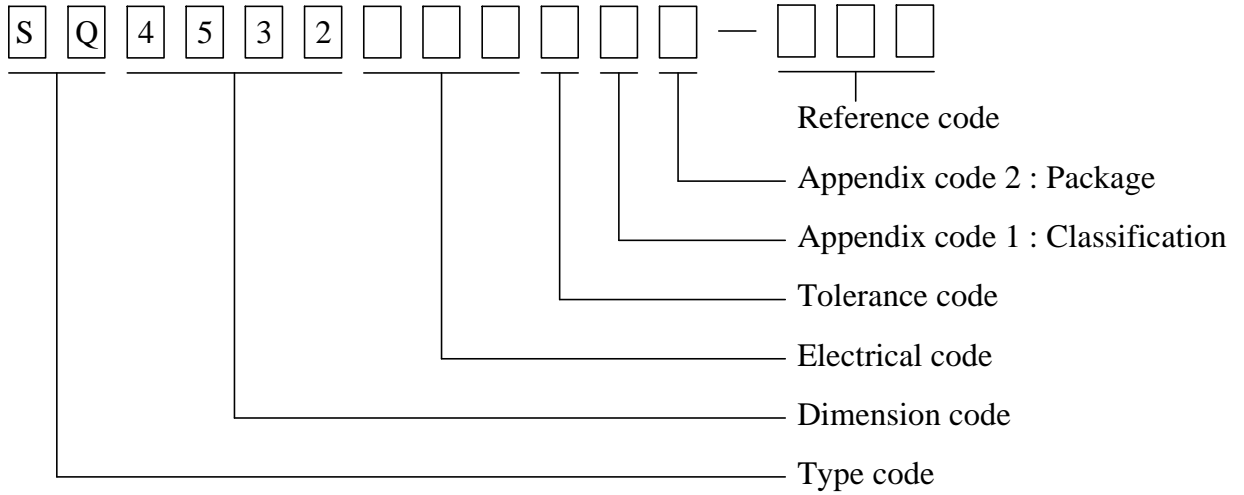

Appendix code 1 : Product Classification

Appendix code 2 : Package Information

Code	Inner package	Cover tape	Carrier tape	Bag	Package Q'TY	Remark
B	T/R (Reel package)	UCT	Antistatic	Antistatic	500 pcs	
C	T/R (Reel package)	UCT	Antistatic	Antistatic	2,000 pcs	

SPECIFICATION FOR APPROVAL

REF. :

PROD. NAME	SMD Power Inductor	ABC'S DWG NO.	SQ4532□□□□L□-□□□		
		REV.	20210123-I	PAGE	6

VIII . Reliability test :

Item	Reference documents	Test Condition	Test Specification
1.High Temperature Exposure	MIL-STD-202 Method 108	1.Temperature: 125±2°C 2.Time:96±2 hours.	1.No mechanical or electrical damage. 2.Inductance shall not change more than ±10%.
2.Temperature Cycling	JESD22-A 104	1.Temperature: -40°C ~ +125°C 2.Number of cycle:100 cycles. 3.Dwell time:30 minutes	1.No mechanical or electrical damage. 2.Inductance shall not change more than ±10%.
3.Biased Humidity Test	MIL-STD-202 Method 103	1.Temperature : 85±2 °C 2.Humidity: 85% RH. 3.Time:96±2 Hours	1.No mechanical or electrical damage. 2.Inductance shall not change more than ±10%.
4.Operational Life	JESD22-A 108	1.Temperature: 125°C(Temp. rise included) 2.Time:96±2 hours. 3.Rated current	1.No mechanical or electrical damage. 2.Inductance shall not change more than ±10%.
5.External Visual	JESD22-B 101 & MIL-STD-883 Method 2009	Inspect product constructions, marking and workmanship.	1.No pollution on the surface of products. 2.Clear marking. 3.No crack.
6.Physical Dimensions	JESD22-B 100	Verify physical dimensions to the applicable product detail specification.	Per product specification standard
7.Resistance to solvents	MIL-STD-202 Method 215	Immerse into solvent for 3±0.5 minutes & brush 10 times for 3 cycles.	1.No body change in appearance. 2.No marking blurred. 3.Inductance shall not change more than ±10%.
8.Vibration Test	MIL-STD-202 Method 204	1.Frequency and Amplitued : 10-2000-10 Hz, 1.5 mm. 2.Direction:X, Y, Z 3.Test duration:2 hours for each direction, 6 hours in total.	1.No mechanical or electrical damage. 2.Inductance shall not change more than ±10%.
9.Resistance To Soldering Heat Test	MIL-STD-202 Method 210 & J-STD020D.1	1.Highest temperature : 250±5°C. 2.Time (temp.≥ 217°C) : 60~150 Seconds. 3.IR reflow times : 3 times.	1.No mechanical or electrical damage. 2.Inductance shall not change more than ±10%.
10.Saturation Current	JIS C 6436 & User SPEC.	1.Applied rated current for 5 seconds. 2.Saturation current	Inductance shall not drop more than 10% max.
11.Over load	JIS C 6436 & User SPEC.	1.Applied one and half rated current for a period of 5 minutes. 2.Rated current	No electrical or mechanical damage
12.Temperature Rise Current	JIS C 6436 & User SPEC.	1.Applied rated current for 10 minutes. 2.Temperature measure by digital surface thermometer. 3.Irms current	Surface temperature rise is less than 40°C max
13.Solderability Test	J-STD-002 & JESD22-B 102	1.Baking in pre-testing : 150±5°C / 16Hours±30 min. 2.Peak temperature : 240±5°C 3.Time (temp.≥ 217°C) : 60~150 seconds. 4.IR reflow times : 1 time.	More than 95% soldering coverage min on terminations.
14.Electrical Characteriazation	MIL-STD-202 Method 304 & User SPEC.	1.Operating temperature : -40°C~125°C 2.Room temperature : 25°C.	1.No mechanical or electrical damage. 2.Inductance shall not change more than ±10%.
15.Drop	CNS-C6354 & GB/T 2423.8	1.Products shall be mounted on SPEC. pcb and dropped down from a heigh of 1m 2.Drop total time : 6 time (Every side ofsample drop 2 times)	1. Adhesion on PCB shall be enough. 2. Product appearance shall not break. 3. No electrical damage.
16.Terminal Strength Test	IEC 60068-2-21	1.Apply push force to samples mounted on PCB. 2.Force of 1.8 kg for 60±1 seconds.	After test, inductors shall be no mechanical damage.

AR-001C