

# SPECIFICATION FOR APPROVAL

REF. :

PROD. NAME	Shielded SMD Power Inductor	ABC'S DWG NO.	QS5818□□□□L□-□□□		
		REV.	20191106-E	PAGE	1

## I . Configuration and dimensions :

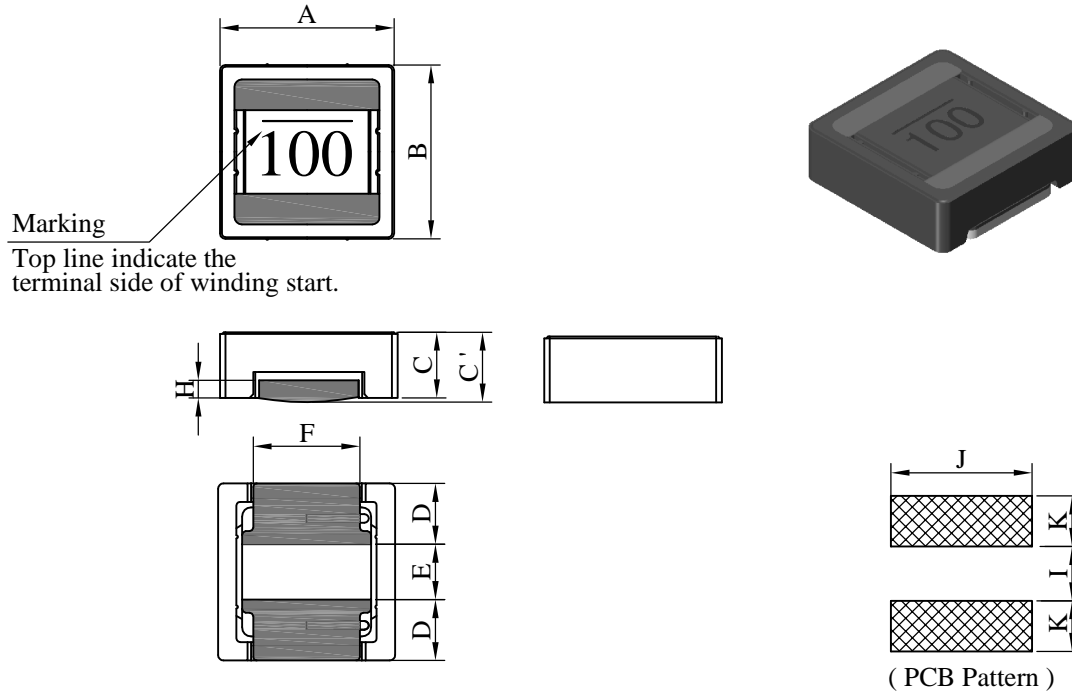

Unit : mm

A	B	C	C'	D	E	F	H	I	J	K
5.80 ±0.30	5.80 ±0.30	1.80 ±0.20	2.20 max.	1.90 typ.	2.00 typ.	3.40 ±0.20	0.50 ±0.20	1.70 ref.	4.85 ref.	2.30 ref.

## II . Description :

- a . Ferrite drum core construction
- b . Magnetically shielded
- c . Enamelled copper wire : H class
- d . Product weight : 0.25g (ref.)
- e . Moisture sensitivity Level 1
- f . Products comply with RoHS' requirements
- g . Halogen free

Peak Temp : 260°C max.  
Max. Peak Temp - 5°C : 30sec max.  
Max time above 217°C : 60sec~150sec max.

## III . General specification :

- a . Storage temp. : -40°C ----+125°C
- b . Operating temp. : -40°C ----+125°C  
(Temp. rise included)
- c . Resistance to solder heat : 260°C .10 secs.

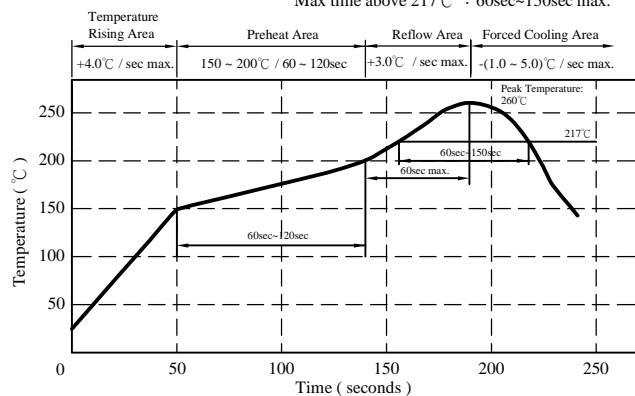

AR-001C

# SPECIFICATION FOR APPROVAL

REF. :

PROD. NAME	Shielded SMD Power Inductor	ABC'S DWG NO.	QS5818□□□□L□-□□□		
		REV.	20191106-E	PAGE	2

IV . Electrical characteristics :

DWG. No.	Inductance ( $\mu$ H)	SRF ( MHz ) typ.	RDC ( m $\Omega$ )		Isat ( A ) typ.	Irms1 ( A ) typ.	Irms2 ( A ) typ.
			typ.	max.			
QS58181R5YL□-□□□	1.5 $\pm$ 30%	100.0	24.0	31.0	3.900	3.000	4.800
QS58182R0YL□-□□□	2.0 $\pm$ 30%	83.0	33.0	43.0	3.200	2.500	3.500
QS58183R0YL□-□□□	3.0 $\pm$ 30%	73.0	58.0	75.0	2.700	1.900	2.650
QS58183R9YL□-□□□	3.9 $\pm$ 30%	63.0	72.0	94.0	2.400	1.700	2.400
QS58185R0YL□-□□□	5.0 $\pm$ 30%	56.0	83.0	108.0	2.100	1.600	2.200
QS58186R2YL□-□□□	6.2 $\pm$ 30%	51.0	95.0	123.0	1.900	1.500	2.000
QS58187R5YL□-□□□	7.5 $\pm$ 30%	43.0	115.0	152.0	1.750	1.350	1.700
QS58189R0YL□-□□□	9.0 $\pm$ 30%	38.0	140.0	185.0	1.600	1.200	1.600
QS5818100ML□-□□□	10.0 $\pm$ 20%	30.0	180.0	235.0	1.450	1.100	1.500
QS5818120ML□-□□□	12.0 $\pm$ 20%	29.0	195.0	250.0	1.350	1.000	1.450
QS5818150ML□-□□□	15.0 $\pm$ 20%	25.0	230.0	300.0	1.200	0.900	1.300
QS5818180ML□-□□□	18.0 $\pm$ 20%	23.0	280.0	365.0	1.150	0.850	1.200
QS5818220ML□-□□□	22.0 $\pm$ 20%	21.0	365.0	475.0	0.980	0.750	1.050
QS5818270ML□-□□□	27.0 $\pm$ 20%	20.0	410.0	510.0	0.900	0.700	0.950
QS5818330ML□-□□□	33.0 $\pm$ 20%	18.0	455.0	570.0	0.830	0.650	0.900
QS5818390ML□-□□□	39.0 $\pm$ 20%	15.0	570.0	710.0	0.750	0.600	0.850
QS5818470ML□-□□□	47.0 $\pm$ 20%	14.0	650.0	810.0	0.680	0.570	0.800
QS5818560ML□-□□□	56.0 $\pm$ 20%	13.0	700.0	875.0	0.630	0.550	0.750
QS5818680ML□-□□□	68.0 $\pm$ 20%	11.0	965.0	1205.0	0.560	0.470	0.580
QS5818820ML□-□□□	82.0 $\pm$ 20%	10.0	1135.0	1420.0	0.520	0.430	0.550
QS5818101ML□-□□□	100.0 $\pm$ 20%	9.0	1515.0	1890.0	0.470	0.370	0.520
QS5818121ML□-□□□	120.0 $\pm$ 20%	8.0	1690.0	2110.0	0.420	0.350	0.500
QS5818151ML□-□□□	150.0 $\pm$ 20%	7.0	2140.0	2675.0	0.380	0.310	0.440
QS5818181ML□-□□□	180.0 $\pm$ 20%	6.0	2700.0	3245.0	0.340	0.280	0.350
QS5818221ML□-□□□	220.0 $\pm$ 20%	5.0	3400.0	4080.0	0.320	0.240	0.330

- 1). Electrical specifications at 25°C
- 2). Inductance Test condition : 100kHz /0.1V
- 3). Isat base on  $\Delta$ L / L0A=35% typ.(Approximately transient current )
- 4). Irms1 base on Temp. rise 20°C typ.
- 5). Irms2 base on Temp. rise 40°C typ.

# SPECIFICATION FOR APPROVAL

REF. :

PROD. NAME	Shielded SMD Power Inductor	ABC'S DWG NO.	QS5818□□□□L□-□□□		
		REV.	20191106-E	PAGE	3

V . Curve :

QS58181R5YL□

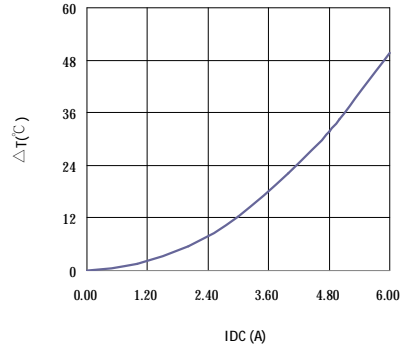
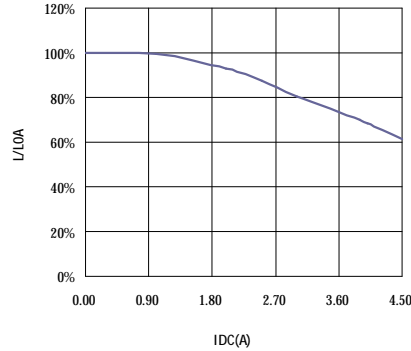

QS5818100ML□

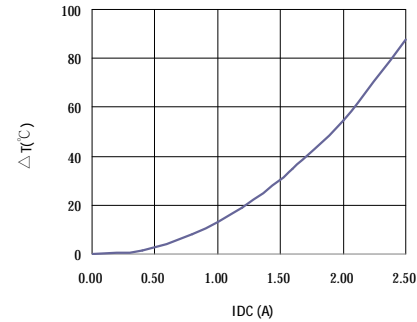
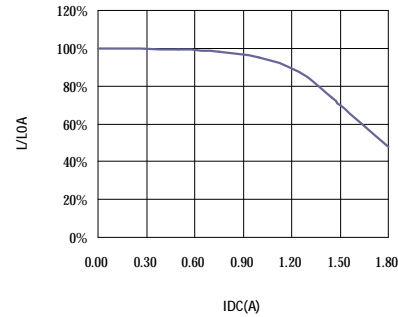

QS5818330ML□

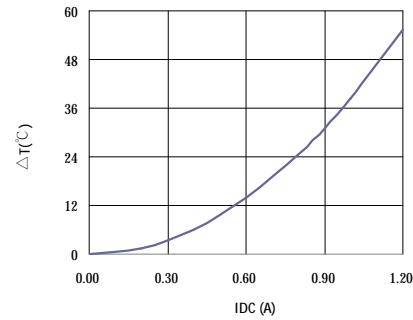
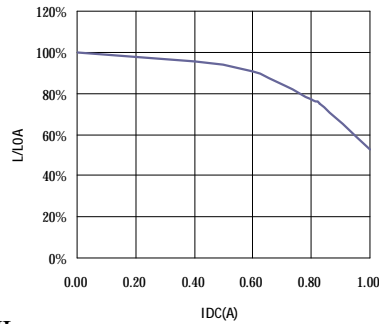

QS5818221ML□

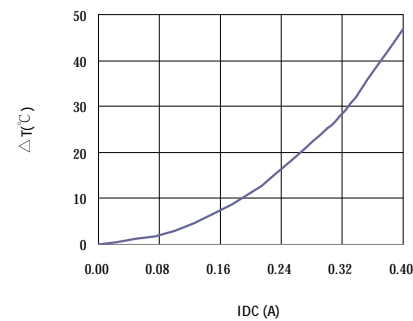
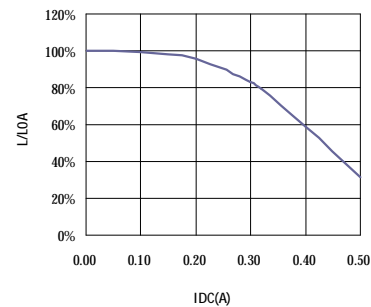

AR-001C

# SPECIFICATION FOR APPROVAL

REF. :

PROD. NAME	Shielded SMD Power Inductor	ABC'S DWG NO.	QS5818□□□□L□-□□□		
		REV.	20191106-E	PAGE	4

## VI . Packaging information :

### ( 1 ) Configuration

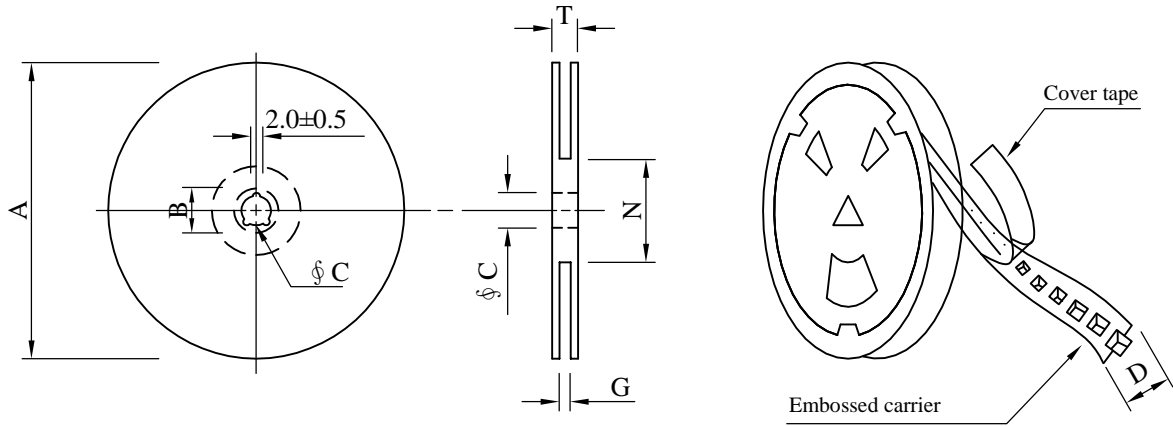

※Carrier tape width : D

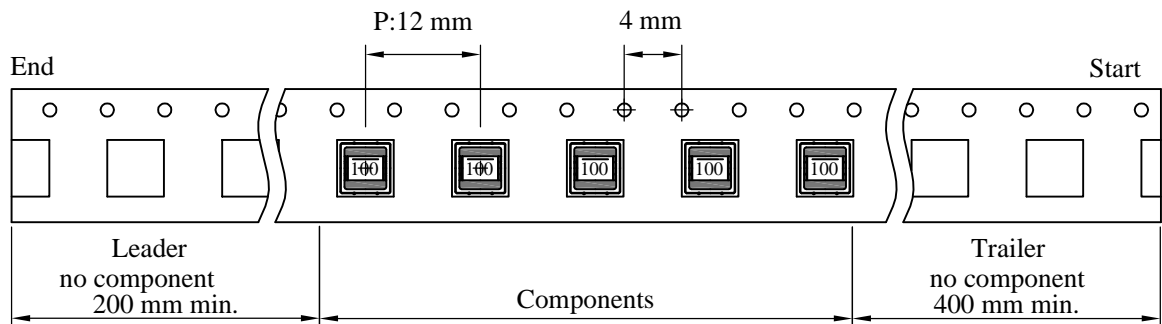

### ( 2 ) Dimensions

User direction of feed →

Unit:mm

Style	A	B	C	D	G	N	T
07 - 16	178	21±0.8	13	16	18 <sup>+0</sup>	50 <sup>-0</sup>	20.5
13 - 16	330	21±0.8	13±0.5	16	18 <sup>+0</sup>	50 <sup>-0</sup>	22.4

### ( 3 ) Q'TY & G.W. Per package

Code	Inner : Reel			Outer : Carton		
	Q'TY (pcs)	G.W. (g)	Style	Q'TY (pcs)	G.W. (kg)	Size (cm)
B	500	235	07 - 16	15,000	8.5	42 x 41 x 24
C	1,800	850	13 - 16	10,800	6.4	38 x 37 x 22

AR-001C



# SPECIFICATION FOR APPROVAL

REF. :

PROD. NAME	Shielded SMD Power Inductor	ABC'S DWG NO.	QS5818□□□□L□-□□□		
		REV.	20191106-E	PAGE	6

## VIII . Reliability test :

Item	Reference documents	Test Condition	Test Specification
1.High Temperature Exposure	MIL-STD-202 Method 108	1.Temperature: 125±2℃ 2.Time:96±2 hours.	1.No mechanical or electrical damage. 2.Inductance shall not change more than ±20%.
2.Temperature Cycling	JESD22-A 104	1.Temperature: -40℃ ~ +125℃ 2.Number of cycle:100 cycles 3.Dwell time:30 minutes	1.No mechanical or electrical damage. 2.Inductance shall not change more than ±20%.
3.Biased Humidity Test	MIL-STD-202 Method 103	1.Temperature : 85±2 ℃ 2.Humidity: 85% RH. 3.Time:96±2 Hours	1.No mechanical or electrical damage. 2.Inductance shall not change more than ±20%.
4.Operational Life	JESD22-A 108	1.Temperature: 125℃ (Temp. rise included) 2.Time:96±2 hours. 3.Rated current :	1.No mechanical or electrical damage. 2.Inductance shall not change more than ±20%.
5.External Visual	JESD22-B 101 & MIL-STD-883 Method 2009	Inspect product constructions, marking and workmanship.	1.No pollution on the surface of products. 2.Clear marking. 3.No crack.
6.Physical Dimensions	JESD22-B 100	Verify physical dimensions to the applicable product detail specification.	Per product specification standard
7.Resistance to solvents	MIL-STD-202 Method 215	Immerse into solvent for 3±0.5 minutes & brush 10 times for 3 cycles.	1.No body change in appearance. 2.No marking blurred. 3.Inductance shall not change more than ±20%.
8.Vibration Test	MIL-STD-202 Method 204	1.Frequency and Amplitued : 10-2000-10 Hz, 1.5 mm. 2.Direction:X, Y, Z 3.Test duration:2 hours for each direction, 6 hours in total.	1.No mechanical or electrical damage. 2.Inductance shall not change more than ±20%.
9.Resistance To Soldering Heat Test	MIL-STD-202 Method 210 & J-STD020D.1	1.Highest temperature : 260±5℃. 2.Time ( temp. ≥ 217℃ ) : 60~150 Seconds. 3.IR reflow times : 3 times.	1.No mechanical or electrical damage. 2.Inductance shall not change more than ±20%.
10.Saturation Current	JIS C 6436 & User SPEC.	1.Applied rated current for 5 seconds. 2.Saturation current :	Inductance shall not drop more than 35% typ.
11.Over load	JIS C 6436 & User SPEC.	1.Applied one and half rated current for a period of 5 minutes. 2.Rated current :	No electrical or mechanical damage
12.Temperature Rise Current	JIS C 6436 & User SPEC.	1.Applied rated current for 10 minutes. 2.Temperature measure by digital surface thermometer. 3.Irms current :	Surface temperature rise is less than 40℃ typ.
13.Solderability Test	J-STD-002 & JESD22-B 102	1.Baking in pre-testing : 150±5℃ / 16Hours±30 min. 2.Peak temperature : 240±5℃ 3.Time ( temp. ≥ 217℃ ) : 60~150 seconds. 4.IR reflow times : 1 time.	More than 95% soldering coverage min. on terminations.
14.Electrical Characteriazation	MIL-STD-202 Method 304 & User SPEC.	1.Operating temperature : -40℃~125℃ 2.Room temperature : 25℃.	1.No mechanical or electrical damage. 2.Inductance shall not change more than ±20%.
15.Drop	CNS-C6354 & GB/T 2423.8	1.Products shall be mounted on SPEC. pcb and dropped down from the height of 1m 2.Drop total times : 6 times (Every side of sample drop 2 times)	1. Adhesion on PCB shall be enough. 2. Product appearance shall not break. 3. No electrical damage.
16.Terminal Strength Test	IEC 60068-2-21	1.Apply push force to samples mounted on PCB. 2.Force of 1.8 kg for 60±1 seconds.	After test, inductors shall be no mechanical damage.

AR-001C