

# SPECIFICATION FOR APPROVAL

REF. :

PROD. NAME	Shielded SMD Power Inductor	ABC'S DWG NO.		SU5018□□□□L□-□□			
		REV.	20201009-G	PAGE	1		

## I . Configuration and dimensions :

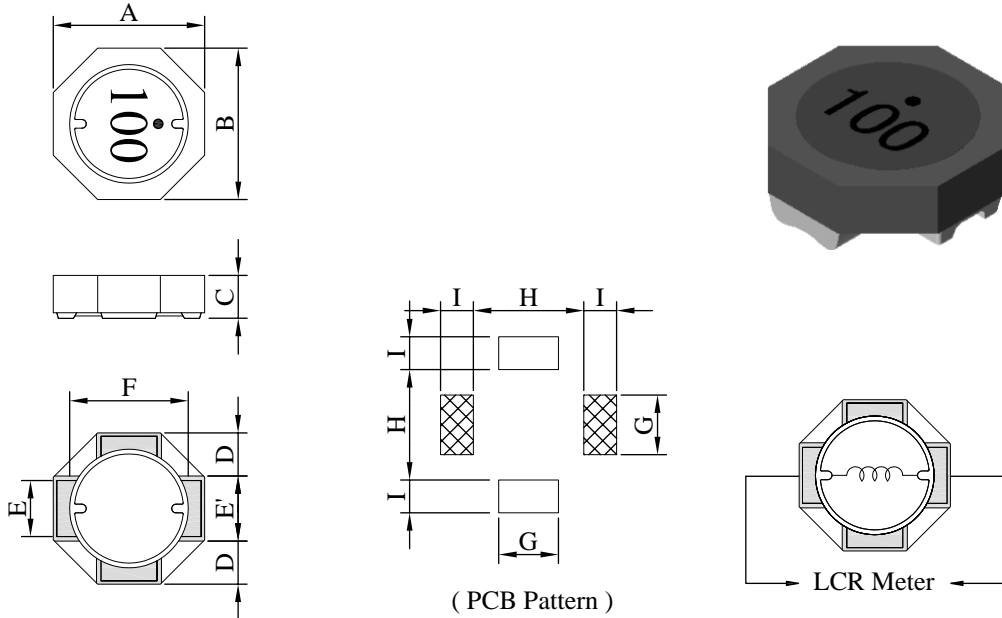

Unit : mm

A	B	C	D	E	E'	F	G	H	I
5.20 ±0.20	5.20 ±0.20	1.80 ±0.20	1.40 typ.	1.80 typ.	2.40 ±0.4	3.90 typ.	2.00 ref.	3.70 ref.	1.10 ref.

## II . Description :

- a . Ferrite drum core construction
- b . Magnetically shielded
- c . Enamelled copper wire : F 、 H class
- d . Product weight : 0.17g ( ref. )
- e . Moisture sensitivity Level 1
- f . Products comply with RoHS' requirements
- g . Halogen free

Peak Temp. : 260°C max.  
Max. Peak Temp. - 5°C : 30sec. max.  
Max. time above 217°C : 60sec.~150sec. max.

## III . General specification :

- a . Storage temp. : -40°C ----+125°C
- b . Operating temp. : -40°C ----+125°C  
( Temp. rise included. )
- c . Resistance to solder heat : 260°C.10 sec.

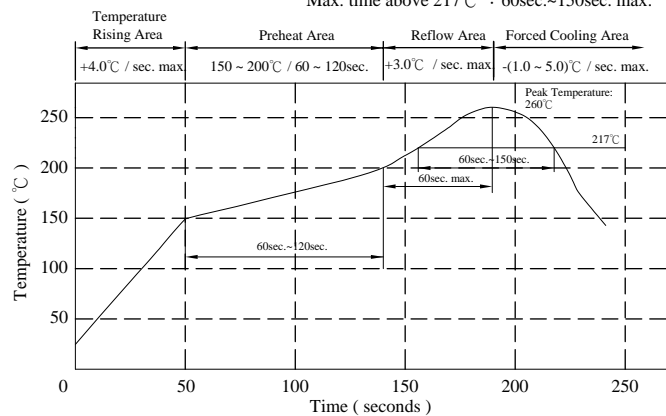

AR-001C

# SPECIFICATION FOR APPROVAL

REF. :

PROD. NAME	Shielded SMD Power Inductor	ABC'S DWG NO.	SU5018□□□□L□-□□□		
		REV.	20201009-G	PAGE	2

IV . Electrical characteristics :

DWG No.	Inductance ( $\mu$ H)	Q ref.	Test Freq. ( Hz )		RDC ( m $\Omega$ )		SRF ( MHz ) typ.	Irms ( mA ) max.	Isat ( mA ) typ.
			L	Q	typ.	max.			
SU50181R0YL□-□□□	1.0 $\pm$ 30 %	9.0	100k	7.96M	12.5	16.5	200	2800	2850
SU50181R5YL□-□□□	1.5 $\pm$ 30 %	9.0	100k	7.96M	15.5	20.5	160	2500	2400
SU50182R2YL□-□□□	2.2 $\pm$ 30 %	10.0	100k	7.96M	20.5	27.0	130	2300	2100
SU50183R5YL□-□□□	3.5 $\pm$ 30 %	9.0	100k	7.96M	32.0	42.0	90	2100	1700
SU50184R7YL□-□□□	4.7 $\pm$ 30 %	8.5	100k	7.96M	36.0	47.0	80	2000	1550
SU50186R8YL□-□□□	6.8 $\pm$ 30 %	7.5	100k	7.96M	50.0	65.0	60	1450	1200
SU5018100YL□-□□□	10.0 $\pm$ 30 %	12.0	100k	2.52M	65.0	85.0	50	1250	1050
SU5018150YL□-□□□	15.0 $\pm$ 30 %	12.0	100k	2.52M	100.0	130.0	40	950	800
SU5018220YL□-□□□	22.0 $\pm$ 30 %	12.0	100k	2.52M	160.0	210.0	28	680	650
SU5018330YL□-□□□	33.0 $\pm$ 30 %	13.0	100k	2.52M	220.0	290.0	23	660	560
SU5018470YL□-□□□	47.0 $\pm$ 30 %	13.0	100k	2.52M	330.0	430.0	18	540	450
SU5018680YL□-□□□	68.0 $\pm$ 30 %	12.0	100k	2.52M	480.0	620.0	16	370	360
SU5018101YL□-□□□	100.0 $\pm$ 30 %	15.0	100k	796k	620.0	780.0	15	320	310

- 1) . Electrical specifications at 25°C
- 2) . Inductance Test Freq. : 100kHz / 0.1V
- 3) . Isat base on  $\Delta$ L / LOA=35% typ.
- 4) . Irms base on Temp. rise 30°C max.

AR-001C

# SPECIFICATION FOR APPROVAL

REF. :

PROD. NAME	Shielded SMD Power Inductor	ABC'S DWG NO.		SU5018□□□□L□-□□□	
		REV.	20201009-G	PAGE	3

V . Curve :

SU50181R5YL□

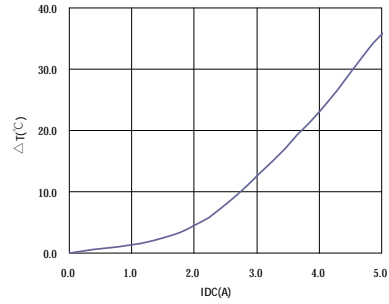
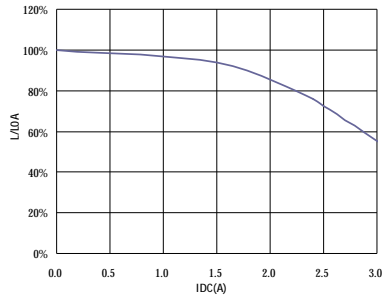

SU5018100YL□

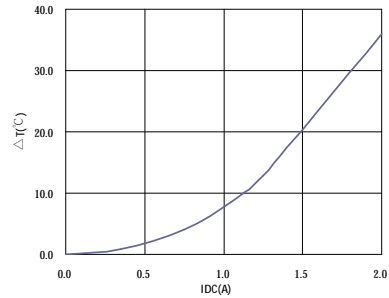
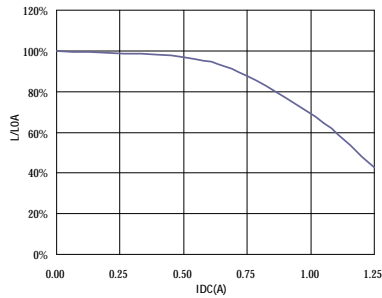

SU5018330YL□

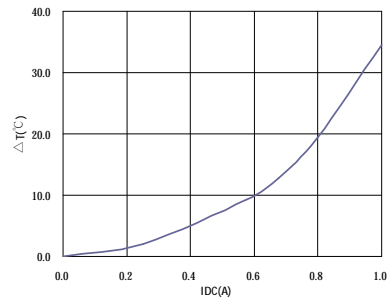
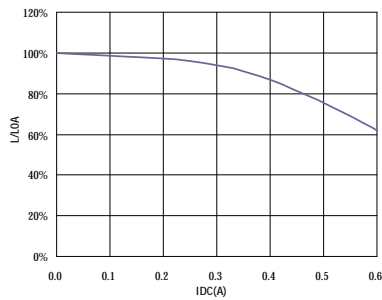

SU5018101YL□

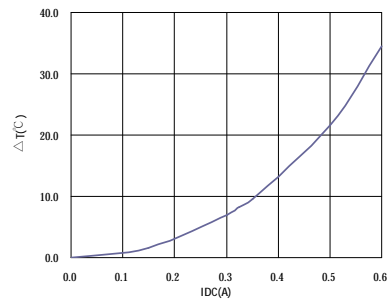
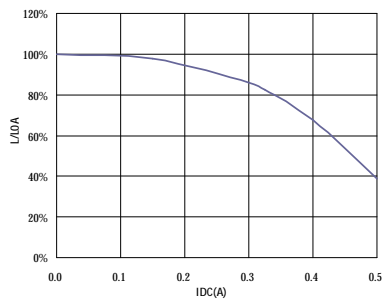

AR-001C

# SPECIFICATION FOR APPROVAL

REF. :

PROD. NAME	Shielded SMD Power Inductor	ABC'S DWG NO.		SU5018□□□□L□-□□□	
		REV.	20201009-G	PAGE	4

## VI . Packaging information :

### ( 1 ) Configuration

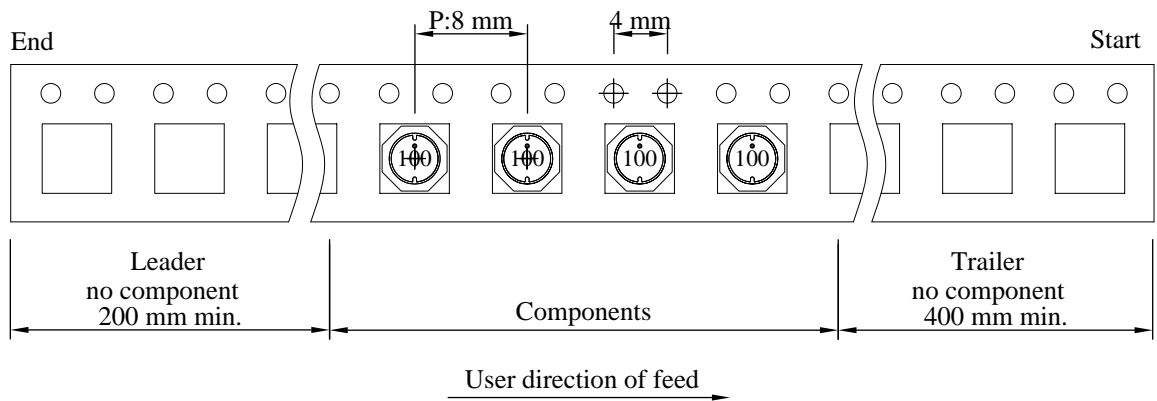
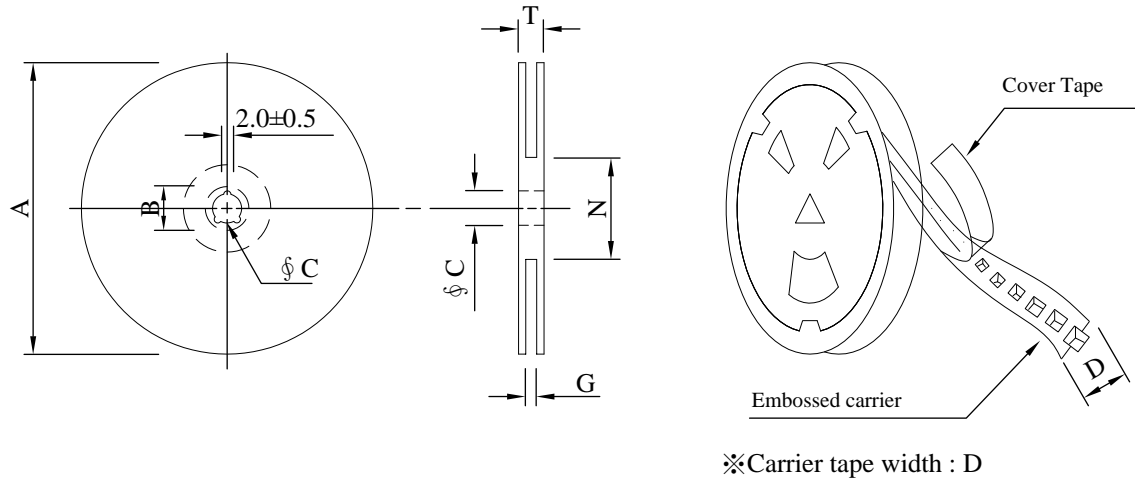

### ( 2 ) Dimensions

Unit:mm

Style	A	B	C	D	G	N	T
07 - 12	178	21±0.8	13	12	14 <sup>+0</sup>	50 <sup>-0</sup>	16.5
13 - 12	330	21±0.8	13±0.5	12	14 <sup>+0</sup>	50 <sup>-0</sup>	18.4

### ( 3 ) Q'TY & G.W. Per package

Code	Inner : Reel			Outer : Carton		
	Q'TY (pcs)	G.W. (g)	Style	Q'TY (pcs)	G.W. (kg)	Size (cm)
B	1,000	270	07 - 12	40,000	12.0	42 x 41 x 24
C	3,500	930	13 - 12	28,000	8.7	38 x 37 x 22

AR-001C

# SPECIFICATION FOR APPROVAL

REF. :

PROD. NAME	Shielded SMD Power Inductor	ABC'S DWG NO.	SU5018□□□□L□-□□□		
		REV.	20201009-G	PAGE	5

VII . Drawing number expression :

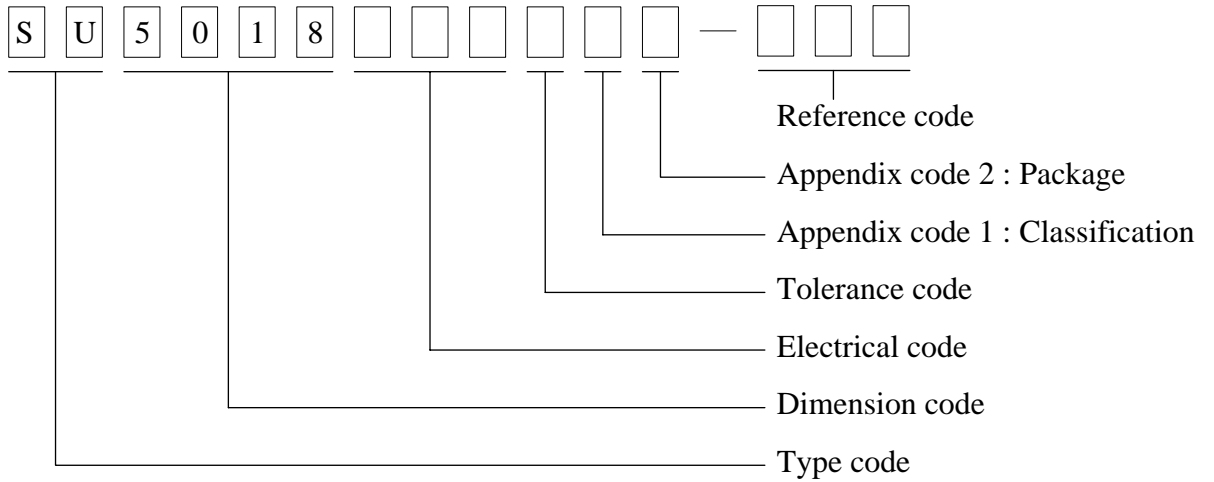

Appendix code 1 : Product Classification

Appendix code 2 : Package Information

Code	Inner package	Cover tape	Carrier tape	Bag	Package Q'TY	Remark
B	T /R (Reel package)	UCT	Antistatic	Antistatic	1,000 pcs	
C	T /R (Reel package)	UCT	Antistatic	Antistatic	3,500 pcs	

# SPECIFICATION FOR APPROVAL

REF. :

PROD. NAME	Shielded SMD Power Inductor	ABC'S DWG NO.	SU5018□□□□L□-□□□		
		REV.	20201009-G	PAGE	6

## VIII . Reliability test :

Item	Reference documents	Test Condition	Test Specification
1.High Temperature Exposure	MIL-STD-202 Method 108	1.Temperature: 125±2℃ 2.Time:96±2 hours.	1.No mechanical or electrical damage. 2.Inductance shall not change more than ±20%.
2.Temperature Cycling	JESD22-A 104	1.Temperature: -40℃ ~ +125℃ 2.Number of cycle:100 cycles 3.Dwell time:30 minutes	1.No mechanical or electrical damage. 2.Inductance shall not change more than ±20%.
3.Biased Humidity Test	MIL-STD-202 Method 103	1.Temperature : 85±2 ℃ 2.Humidity: 85% RH. 3.Time:96±2 Hours	1.No mechanical or electrical damage. 2.Inductance shall not change more than ±20%.
4.Operational Life	JESD22-A 108	1.Temperature: 125℃(Temp. rise included) 2.Time:96±2 hours. 3.Rated current	1.No mechanical or electrical damage. 2.Inductance shall not change more than ±20%.
5.External Visual	JESD22-B 101 & MIL-STD-883 Method 2009	Inspect product constructions, marking and workmanship.	1.No pollution on the surface of products. 2.Clear marking. 3.No crack.
6.Physical Dimensions	JESD22-B 100	Verify physical dimensions to the applicable product detail specification.	Per product specification standard
7.Resistance to solvents	MIL-STD-202 Method 215	Immerse into solvent for 3±0.5 minutes & brush 10 times for 3 cycles.	1.No body change in appearance. 2.No marking blurred. 3.Inductance shall not change more than ±20%.
8.Vibration Test	MIL-STD-202 Method 204	1.Frequency and Amplitued : 10-2000-10 Hz, 1.5 mm. 2.Direction:X, Y, Z 3.Test duration:2 hours for each direction, 6 hours in total.	1.No mechanical or electrical damage. 2.Inductance shall not change more than ±20%.
9.Resistance To Soldering Heat Test	MIL-STD-202 Method 210 & J-STD020D.1	1.Highest temperature : 260±5℃. 2.Time ( temp. ≥ 217℃ ) : 60~150 Seconds. 3.IR reflow times : 3 times.	1.No mechanical or electrical damage. 2.Inductance shall not change more than ±20%.
10.Saturation Current	JIS C 6436 & User SPEC.	1.Applied rated current for 5 seconds. 2.Saturation current	Inductance shall not drop more than 35% typ.
11.Over load	JIS C 6436 & User SPEC.	1.Applied one and half rated current for a period of 5 minutes. 2.Rated current	No electrical or mechanical damage
12.Temperature Rise Current	JIS C 6436 & User SPEC.	1.Applied rated current for 10 minutes. 2.Temperature measure by digital surface thermometer. 3.Irms current	Surface temperature rise is less than 30℃ max.
13.Solderability Test	J-STD-002 & JESD22-B 102	1.Baking in pre-testing : 150±5℃ / 16Hours±30 min. 2.Peak temperature : 240±5℃ 3.Time ( temp. ≥ 217℃ ) : 60~150 seconds. 4.IR reflow times : 1 time.	More than 95% soldering coverage min on terminations.
14.Electrical Characteriazation	MIL-STD-202 Method 304 & User SPEC.	1.Operating temperature : -40℃~125℃ 2.Room temperature : 25℃.	1.No mechanical or electrical damage. 2.Inductance shall not change more than ±20%.
15.Drop	CNS-C6354 & GB/T 2423.8	1.Products shall be mounted on SPEC. PCB and dropped down from a height of 1m 2.Drop total time : 6 times (Every side of sample drop 2 times)	1. Adhesion on PCB shall be enough. 2. Product appearance shall not break. 3. No electrical damage.
16.Terminal Strength Test	IEC 60068-2-21	1.Apply push force to samples mounted on PCB. 2.Force of 1.8 kg for 60±1 seconds.	After test, inductors shall be no mechanical damage.

AR-001C



千如電子集團  
ABC-ATEC ELECTRONICS GROUP